

## ITL Part Code - VF-106



### Specifications:

Sealing Mechanism: Welded Bellows

Material exposed to Vacuum: Stainless Steel

Bakeout Temperature: 200°C

Operating Temperature: -20° to 150°C

Pressure Range: Atmosphere to 1 x 10<sup>-11</sup> Torr

Position Lock: Thumb Screw

Maximum Torque: 125 oz./in.

Scale Resolution: 5°

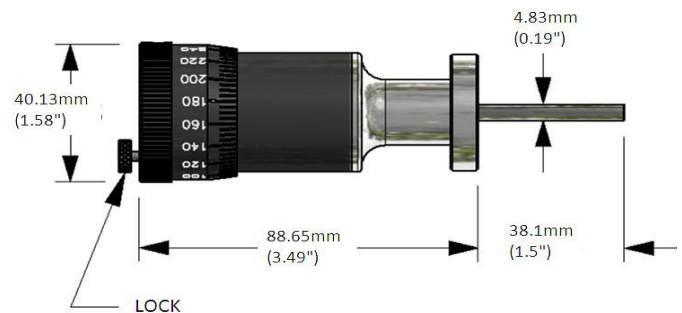

### VAC-U-FLANGE® Series

Flange	Description
1 1/3"	Rotary feedthrough, Anodized w/ dial

The VF-106 series can be motorised.

**Specialist UK manufacturers and suppliers of standard and bespoke vacuum products.**

**For all enquiries please contact us on:**